

Caution:

Hold the head of the bolt to prevent it from slipping out of place as you press the legs onto the bolts. If a bolt does come out, align the square shoulders to match the hole in the frame and press it back into place. Misalignment may cause the bolt head slip when you tighten the wing nuts during use.

6. Leg Braces -

With the legs in the folded position, place each leg brace across the legs so that the edge facing the end of the unit is flush with the outer face of the cross support (see **Fig. 12**) and screw them into place with (2) screws at each end.

Leg assembly detail

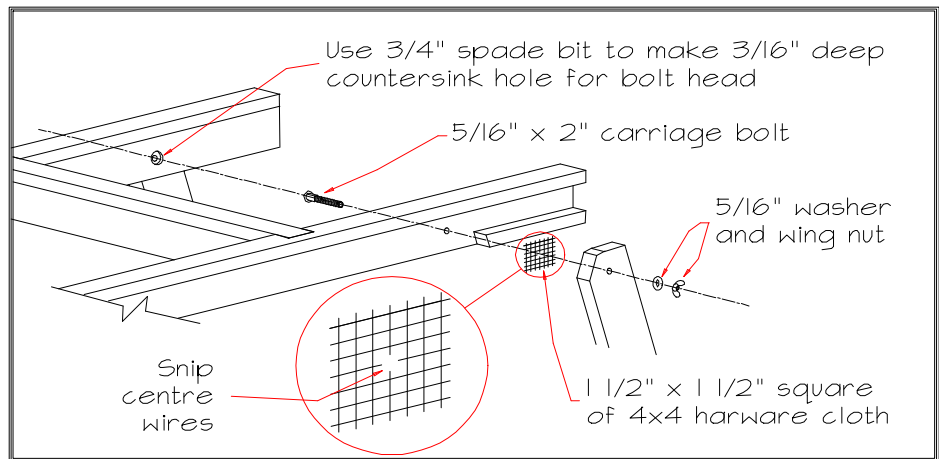

Fig. 11

7. Leg Stops - I usually leave these a little long until I'm ready to attach them. Make a 15 degree cut at one end. Clamp it into position and check the leg rotation for clearance. Once you've found the proper placement for each stop, cut it to length and attach it with glue and (2) 1 1/4 inch screws.

Face down side view

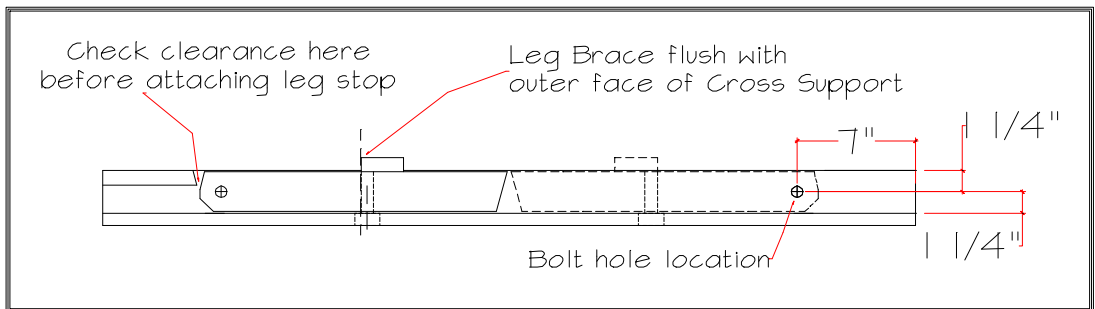

Fig. 12

That's it! For added durability, protect your BEE-Mate with a couple of coats of wax or polyurethane.